

**REDRINK**

**For Service & Installation**

**BBT NORTH AMERICA**  
Bosch Group



**Bosch Water Heating**  
**340 Mad River Park**  
**Waitsfield VT 05673**  
**TOLL FREE**  
**866-330-2729**  
[www.boschhotwater.com](http://www.boschhotwater.com)



*Handbook for*

**PowerStar**  
*electric tankless water heaters*

**MODELS**

<b>AE9.5</b>	<b>AE3.4</b>	<b>AE7.2</b>
<b>240V</b>	<b>120V</b>	<b>240V</b>
<b>208V</b>	<b>110V</b>	<b>220V</b>

---

**IMPORTANT:** This booklet should be given to the customer after installation and demonstration.

## Important safety Instructions

When using this electrical equipment, basic safety precautions should always be followed, including the following:

### 1. READ AND FOLLOW ALL INSTRUCTIONS

2. This appliance must be grounded.
3. Disconnect this product from the electrical supply before cleaning, servicing or removing the cover.
4. To reduce the risk of injury, close supervision is necessary when the product is used near children or elderly persons.
5. Warning: Do not install the heater in a location where it may be subject to freezing.
6. Warning: Do not install a check valve or any other type of back flow preventer within six feet of the cold water inlet.
7. The electrical installation must conform to current National Electrical Codes.
8. Warning: Do not switch the the heater on if you suspect that it may be frozen. Wait until you are sure that it has completely thawed out.
9. The Powerstar is designed to heat potable cold water for domestic purposes. Contact Bosch Water Heating before specifying or installing the appliance in any other application.

#### 10. Additional Canadian Safety Instructions

- (a) A green terminal (or a wire connector marked "G", "GR", "GROUND", OR GROUNDING ) is provided within the control box. To reduce the risk of electric shock, connect this terminal or connector to the grounding terminal of the electric service of supply panel with a continuous copper wire in accordance with the Canadian Electrical Code, Part I.
- (b) This product shall be protected by a Class A ground fault circuit interrupter.

## Contents

Using the Powerstar	3
Installing the Powerstar	3
Spare Parts	6
Starting up the Powerstar	7
How the Powerstar works	8
Troubleshooting	10
Warranty	Back Cover

## SAVE THESE INSTRUCTIONS

Keep this guide in a safe place once your Powerstar unit has been installed.  
You may need to refer to it for general instructions or future maintenance.

## Using the Powerstar

### WARNING

Do not use the unit if you think it may be frozen, as this could result in serious damage to the unit. Wait until you are sure that it has completely thawed out before you switch it on.

### Sink

- Check that the power is switched on at the circuit breaker panel.
- Turn on the hot water tap FULLY. If you do not turn the tap full on, you will find that the temperature of the water will vary. The hot water temperature can then be set by adjusting the flow.
- If the unit has been used recently, run the water through for a few seconds to let the temperature settle down. You may initially get a short burst of very hot water from the unit.
- If a second tap connected to the unit is also turned on, the hot water will be shared between the two, therefore the flow and/or the temperature of the water will decrease.

Diagram 1: Examples of installations

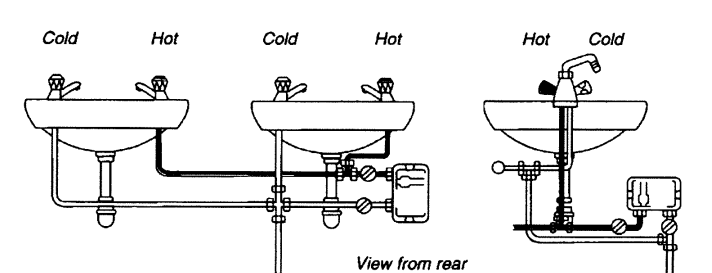

## Installing Powerstar

### WARNING

Do not install the Powerstar in a room where there is a chance of freezing.

### IMPORTANT - Read entire instructions

Check the pressure of the main water supply. To operate correctly, the unit needs the following running pressures-

#### Sink

Min: 10 psi (0.7 bar)  
Max: 150 psi (10.3 bar)

### Securing the unit to the wall

#### Deciding the position

- If being used in a public place, position the unit out of easy reach to discourage vandalism.
- Mount the unit onto a flat section of wall, well away from any potential splashes of water or spray.
- Position the unit either upright or length ways (diagram 1), whichever is most convenient for plumbing and wiring. Remember to keep the lengths of hot water pipe to a minimum in order to save energy.
- If the unit is to supply a sink, you can fit it either above or below the sink.

## Deciding the wiring route

- You have a choice of whether to feed the electric cable through the side or through the back of the unit.
- If it is going through the side of the unit, cut out the plastic lug to expose the rubber sleeve (diagram 2).

Diagram 2: Lug cut out

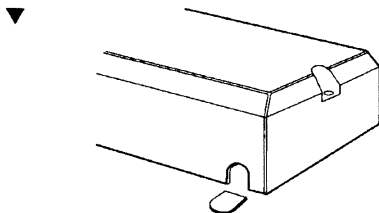

- If it is going through the back of the unit, cut through the grommet on the backplate with a sharp knife. Make sure that you do not remove the grommet from the backplate (diagram 3). Feed the cable through the grommet before you mount the unit to the wall. If you are using an approved cable clamp fitting or conduit fitting, remove the grommet.

Diagram 3: Back of unit

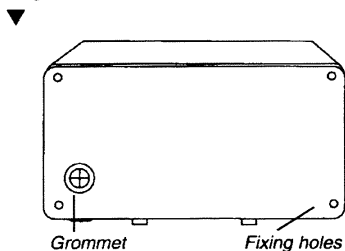

## Mounting on the wall

- Undo the retaining screws on the cover and take the cover off the unit. Hold the backplate in position against the wall while you mark the four mounting holes.
- Drill the holes and secure the unit to the wall using the four No. 8 wood screws supplied.

## Warning IMPORTANT

- Do not install a non-return check valve within 6 feet of the inlet.

## Plumbing in the unit

### Fitting the pipes

- The unit should be connected directly to the main cold water supply and not to pre-heated water. The unit should be installed with service valves on both the inlet and outlet.
- We recommend that you use 1/2" copper or high pressure flex connections.
- Use Teflon tape for sealing pipe threads. Do NOT use a pipe dope.
- Remember to keep the the hot water pipe runs as short as possible. In some cases it may be worth fitting a second unit to serve an additional fixture.
- If the unit is to supply more than one sink, the aerator should be the same at each tap if they are to be used at the same time. If not, one outlet will take all the water.
- After the unit has been plumbed in, and before you wire it, flush it with water to remove any debris or loose particles. Failure to do so may make the unit inoperable.

### Connecting the unit to the pipes

- The inlet and outlet are clearly marked on the unit. They each have a 1/2" NPT connector.
- Install a ball valve in the cold water line. This valve can be used to turn off the water supply to the unit if it needs servicing, or to reduce the water flow if it is too high.
- If the unit is to supply a sink, we recommend that you use aerators, which you can get from your local distributor/dealer.

### DISCLAIMER

*As a condition of installing this product in the Commonwealth of Massachusetts a pressure relief valve shall be installed on the cold water side, by a licensed plumber MGL 142 Section 19 Approval number: P1-09-25*

### Making the electrical connections

Model	Rated Voltage	Rated Current	Recommended Wire Size
AE9.5	240V	40A	8
AE9.5	208V	35A	8
AE3.4	110V	30A	10
AE7.2	240V	30A	10

### WARNING

- The unit must be installed by a qualified electrician.
- The unit must be grounded.

When the Powerstar is not within sight of the electrical circuit breakers, a circuit breaker lockout or additional local means of disconnection for all non grounded conductors must be provided that is within sight of the appliance. (REF NEC 422.31)

### Connecting the unit to power

- Strip back the insulation on the power wires about 3/8". Any insulation on the ground should be stripped back about 3/4".
- Feed the cable through the side or rear entry grommets, as appropriate.
- Connect the cables to the terminal block and ground stud (diagram 4).

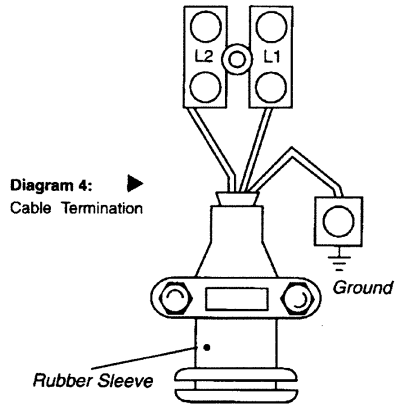

- Make sure that all the terminal block screws are tightened securely. Loose connections can cause wires to heat up.
- Make sure that the ground wire is wrapped around it's terminal stud and into the saddle washer. The nut should be tightened securely.

- Set the Power Selector Screw (diagram 5) on the desired setting. If it is set to LO, only one heating element will operate and the output will be half power. See the table on page 8 for temperature rise at various flow rates. If the element is set on HI, both heating elements will operate and the output will be full power. When setting the Power Selector Screw, it is important that the screw be adjusted all the way to the end of the slot and that it be well tightened.
- Attach the front cover and tighten the retaining screws.

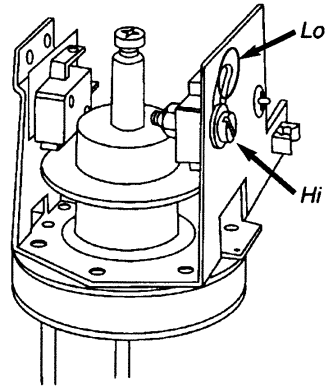

▲ **Diagram 5:**  
Power selector screw

## Spare Parts

93.793701	Backplate
.....	Heat Exchange Assy. (please quote loading/voltage on rating plate when ordering).
93.793703	Terminal Block
93.793798	Front Cover (White).
93.793773	Thermal Cut-Out Assembly (Manual Re-set)
93.793818	Flow Switch
93.793707	Neon Light & Clip
.....	Wiring Assy. (please quote loading/voltage on rating plate when ordering).
93.793709	Cable Clamp & Rubber Boot
93.793713	Cover Retaining Screws

For further information ask your local dealer.

**FOR SERVICE AND INSTALLATION  
QUESTIONS CALL TOLL FREE:**

**866-330-2729**

[www.boschhotwater.com](http://www.boschhotwater.com)

**Bosch Water Heating, 340 Mad River Park, Waitsfield, VT 05673.**

# Starting up the Powerstar

## Checking for leaks

- Let the water run through the unit for a few seconds. Check that no pipe joints leak.

## Adjusting the flow

Turn the service valves on, then -

- turn on the hot water tap fully at the sink.
- adjust the outlet service valve until the water comes out of the tap at the required temperature, (increase flow for cooler, decrease for hotter).

- Check that the unit works correctly when the sink tap is closed and then opened again; if not, adjust the service valve slightly.

- the inlet service valve should not be used to regulate temperature.

**When using the hot water open the tap fully so that the water temperature is always the same. If hotter water is desired decrease the flow.**

### Note

If the unit is servicing a single lever faucet you may need to restrict the cold water supply to the faucet to balance water pressure and improve performance.

### IMPORTANT

Before leaving the site, the installer should demonstrate the unit to the user and give him/her this guide.

▼ **Diagram 6:** Inside view

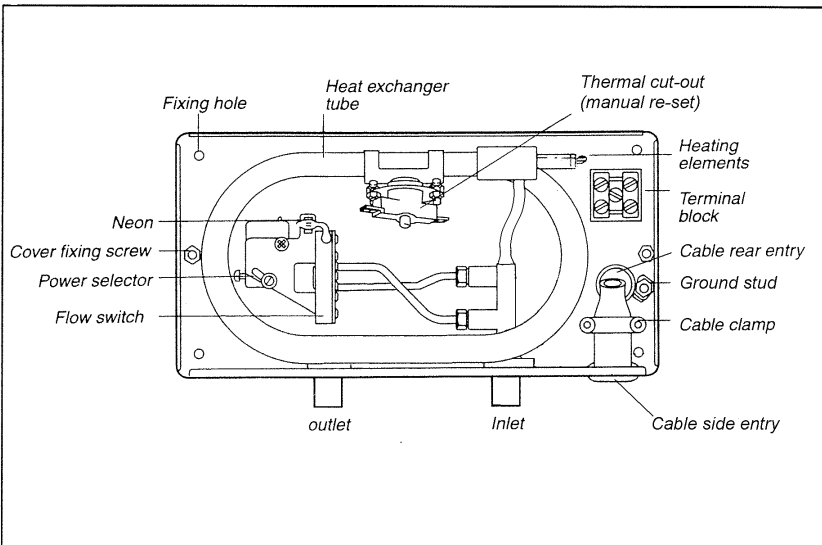

# How the Powerstar works

Water comes in through the inlet tube.

The flow switch senses how much water is passing through the unit. If it detects more than the preset level, the units heating elements switch on. This is shown by the neon light glowing.

The water is heated instantly as it passes through the copper heat exchanger tube.

The temperature of the water coming out of the unit depends on:-

- the voltage of the electrical supply,
- the temperature of the incoming water supply,
- the setting of the power selector,
- the flow rate,
- the power rating of the unit

Depending on the region of the country, the temperature of the water supply can vary from 40°F in winter to about 70°F in summer, with an average of about 50°F.

The chart below shows the rise in water temperature you can expect from the unit.

The unit has a thermal cut-out (diagram 6) which is mounted on the heat exchanger tube. This will switch off the heater elements if the water flow is reduced too much and the temperature goes above 194°F.

If the cut-out trips it will need to be reset manually inside the unit. This cut-out will only operate in exceptional circumstances (diagram 7). Call your service person or Bosch Water Heating if this happens frequently.

▼ Diagram 7: Manual re-set Thermal cut-out

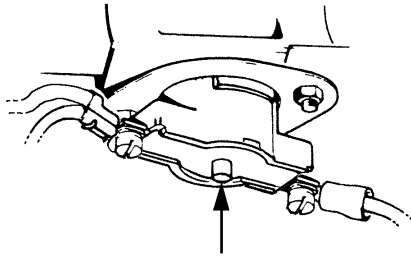

Model	Volts	Amps	Element Resistance	High Setting	Low Setting	Temperature Rise (deg F) at Flow Rate (GPM)					
						0.5GPM	0.75GPM	1.0GPM	1.5GPM	2.0GPM	2.5GPM
AE9.5	240	40	2x12Ω	9.5kW		NA	84F	64F	42F	32F	NA
AE9.5	240	20	1x12Ω		4.75kW	NA	42F	32F	21F	16F	NA
AE9.5	208	35	2x12Ω	7.1kW		NA	64F	48F	32F	24F	NA
AE9.5	208	18	1x12Ω		3.5kW	NA	32F	24F	16F	12F	NA
AE3.4	120-110	27	2x8Ω	3.4-3.0kW		41F	28F	20F	NA	NA	NA
AE7.2	240-220	30	2x16Ω	7.2-6.1kW		96F	63F	48F	32F	24F	NA
AE7.2	240-220	15	1x16Ω		3.6-3.05kW	48F	32F	24F	16F	12F	NA

**Diagram 9: Internal wiring plan** ▼

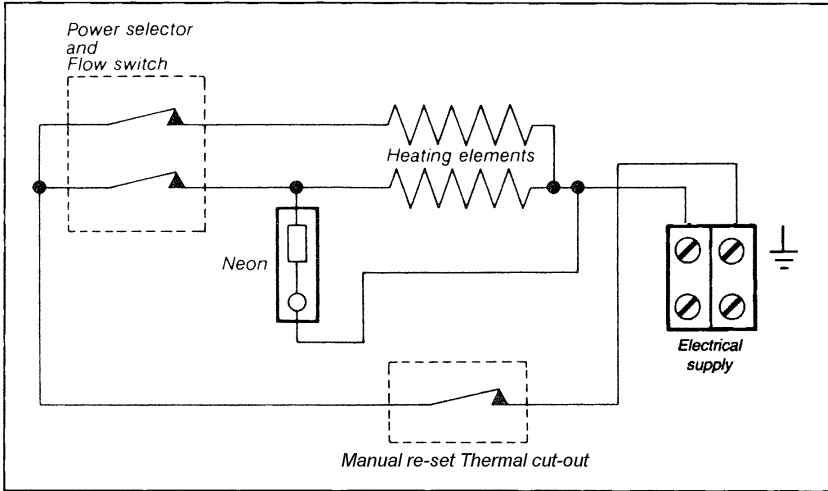

**- Warning**

*Always switch off the electricity supply to the unit before you remove the cover.*

**If you have a problem...**

<b>For the installer</b>		
<b>Symptom</b>	<b>Cause</b>	<b>What to do</b>
<b>Cold water only</b> <b>- neon light off.</b>	<i>Electricity not on.</i>	<i>Check electrical supply</i>
	<i>The water supply is connected to the OUTLET of the unit.</i>	<i>Reconnect the water supply to the INLET (marked in blue).</i>
	<i>The high temperature thermal cut-out has tripped.</i>	<i>Reset it by opening the unit and pushing the button on the cut-out (diagram 7 on page 8). Before you do this you must find the cause of the problem</i>
	<i>The flow switch is not working.</i>	<i>Turn off the power, open the unit and observe if the flow switch activates when the water is turned on. If not contact BBT 866-330-2729 or visit <a href="http://www.boschhotwater.com">www.boschhotwater.com</a></i>
<b>Water too cold</b> <b>- neon light on.</b>	<i>Water flow too high.</i>	<i>Adjust water flow (see chart on page 8)</i>
	<i>The power selector screw not all the way to 'HI'</i>	<i>Change the power select screw to 'HI' (see page 6).</i>
	<i>One element is not working</i>	<i>Switch off the electricity &amp; check the resistance of the elements (See chart on page 8).</i>
	<i>The power supply voltage has dropped.</i>	<i>Check the supply voltage to the heater (see chart on page 8).</i>
<b>Water flow too low, or temperature too high.</b>	<i>There are restrictions in the plumbing.</i>	<i>Check the plumbing. Only use Teflon tape for sealing pipe joints.</i>

**For the User**

<b>Symptom</b>	<b>Cause</b>	<b>What to do</b>
<b>Little or no water flows.</b>	<i>The water supply is turned off.</i>	Turn on the main supply fully at the stop valve.
<b>Cold water only - neon light off.</b>	<i>The flow is not high enough to activate.</i>	Open the inlet service valve fully.
<b>Water too cold - neon light on.</b>	<i>The water flow rate is too high.</i>	Adjust the flow rate (see page 7).
	<i>The inlet water temperature has dropped.</i>	Adjust the flow rate (see page 7).
<b>Water flow too low, or temperature too high.</b>	<i>The main supply of water flow is too low.</i>	Increase the water flow.
	<i>The hot tap is not fully open.</i>	Adjust the stop/ball valve so that water is at the right temperature with the tap fully open (see page 7). Always turn the hot tap full on.
<b>Water temperature fluctuates.</b>	<i>Fluctuating water pressure and/or flow is causing the flow switch to cycle on and off.</i>	<ul style="list-style-type: none"> <li>- Increase the flow rate.</li> <li>- Be sure that the isolation valves are properly adjusted.</li> <li>- Be sure that the inlet filter screen is clean.</li> <li>- Be sure that the outlet restrictors and aerators on showers and/or faucets are clear.</li> <li>- Be sure that there is no plumbing crossover by shutting off the inlet isolation valve and opening all hot water outlets served by the Powerstar. If there is a steady flow, then cold water is flowing into hot water service lines and back-pressuring the Powerstar. This condition must be fixed or the heater will not work properly.</li> </ul>
<b>If the problem persists</b>		
<p>The person who initially installed the unit is probably the best one to contact for help. You can also call BBT on 866-330-2729 or visit <a href="http://www.boschhotwater.com">www.boschhotwater.com</a>. Please have this guide with you when you call.</p>		

# POWERSTAR LIMITED 5 YEAR WARRANTY

## COVERAGE

APPLIED ENERGY PRODUCTS LTD.  
THROUGH ITS U.S. DISTRIBUTOR  
BOSCH WATER HEATING (here in after  
BBT) guarantees this water heater to the Owner  
(here in after "Owner") of the water heater at the  
original installation location against defects in  
material and workmanship for the periods  
specified below.

## WARRANTY PERIOD

1. The Heat Exchanger/Element - if the original heat exchanger leaks or the heating element fails within five (5) years from the date of original installation of the water heater, because of a defect in material or workmanship, BBT will furnish to such Owner a replacement heater of the then prevailing comparable model.

2. Any Component Part Other than The Heat Exchanger/Element - If any other component part (other than the heat exchanger/element) proves to be defective in material or workmanship within one (1) year from the date of original installation of the water heater, BBT will furnish the Owner with a replacement of the defective part(s).

3. Verification of Date of Original Installation - When Owner cannot verify or document the original date of installation, the warranty period begins on the date of manufacture marked on the tag affixed to water heater.

## EXCLUSIONS

1. **THIS LIMITED WARRANTY SHALL BE THE EXCLUSIVE WARRANTY MADE BY THE MANUFACTURER AND IS MADE IN LIEU OF ALL OTHER WARRANTIES, EXPRESSED OR IMPLIED (WHETHER WRITTEN OR ORAL), INCLUDING, BUT NOT LIMITED TO, WARRANTIES OF MERCHANTABILITY AND FITNESS FOR A PARTICULAR PURPOSE.**

2. Manufacturer shall not be liable incidental, consequential, special or contingent damages or expenses arising, directly or indirectly, from any defect in the water heater or the use of the water heater.

3. Manufacturer shall not be liable for any water damage arising, directly or indirectly, from any defect in the water heater component part(s) or from its use.

4. Manufacturer shall not be liable under this warranty if:  
a) The water heater or any of its component parts has been subject to misuse, alteration, neglect or accident or freeze, or  
b) The water heater has not been installed in

accordance with the applicable local plumbing and/or building code(s) and/or regulation(s), or  
c) The water heater has not been installed in accordance with the printed manufacturers instructions, or  
d) The water heater is not continuously supplied with potable water.

5. The OWNER and not the Manufacturer or his representative shall be liable for and shall pay for all field charges for labor or other expenses incurred in the removal and/or repair of the product or any expense incurred by the owner in order to repair the product.

**SOME STATES DO NOT ALLOW THE EXCLUSION OR LIMITATION OF INCIDENTAL OR CONSEQUENTIAL DAMAGES, SO THE ABOVE LIMITATION OR EXCLUSION MAY NOT APPLY TO YOU. THIS WARRANTY GIVES YOU SPECIFIC LEGAL RIGHTS AND YOU MAY ALSO HAVE OTHER**

## IMPORTANT; OWNER SHALL KEEP THIS CERTIFICATE

NOTE: A water heater should be installed in such a manner that if it should leak, the resulting flow of water will not cause damage to the area in which it is installed.

## HOW THE OWNER CAN SECURE SERVICE OR MAKE A CLAIM

1. Owner should contact the dealer who sold the water heater covered by this warranty or
2. Owner should submit the warranty claim directly to BBT at the address listed below, and they will arrange for the handling of the claim.
3. Whenever any inquiry or service request is made, be sure to include the water heater model number the date of manufacture, date of installation, Dealers name and the watts and voltage.
4. When returning the water heater or component part(s) they must be individually tagged and identified with the Returned Goods Authorization # issued by BBT and shipped prepaid to BBT at the address below.

# BBT NORTH AMERICA Bosch Group

Bosch Water Heating.  
340 Mad River Park, Waitsfield. VT 05673  
866-330-2729  
[www.boschwaterheating.com](http://www.boschwaterheating.com)

12.14.05